

LH5164A/AH

PRELIMINARY
CMOS 64K (8K × 8) Static RAM

FEATURES

- 8,192 × 8 bit organization
- Access times: 80/100 ns (MAX.)
- Low-power consumption:
 - Operating:
 - 303 mW (MAX.) LH5164A/D/N @ 80 ns
 - 248 mW (MAX.) LH5164A/D/N/T @ 100 ns
 - 275 mW (MAX.) LH5164AH/HD/HN/HT @ 100 ns
 - Standby:
 - LH5164A/D/N/T: 5.5 μW (MAX.)
 - LH5164AH/HD/HN/HT:
 - T_A ≤ 85°C: 16.5 μW (MAX.)
 - T_A ≤ 70°C: 5.5 μW (MAX.)

- Fully-static operation
- Three-state outputs
- Single +5 V power supply
- TTL compatible I/O
- Wide temperature range available
 - LH5164A: -10 to +70°C
 - LH5164AH: -40 to +85°C
- Packages:
 - 28-pin, 600-mil DIP
 - 28-pin, 300-mil SK-DIP
 - 28-pin, 450-mil SOP
 - 28-pin, 8 × 13 mm² TSOP (Type I)

DESCRIPTION

The LH5164A/AH are static RAMs organized as 8,192 × 8 bits. It is fabricated using silicon-gate CMOS process technology.

The LH5164AH is designed for wide temperature range from -40 to +85°C.

PIN CONNECTIONS

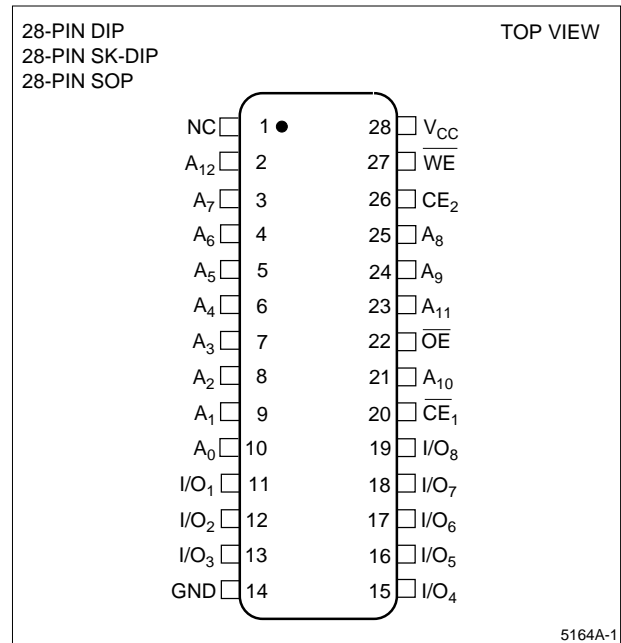

Figure 1. Pin Connections for DIP, SK-DIP, and SOP Packages

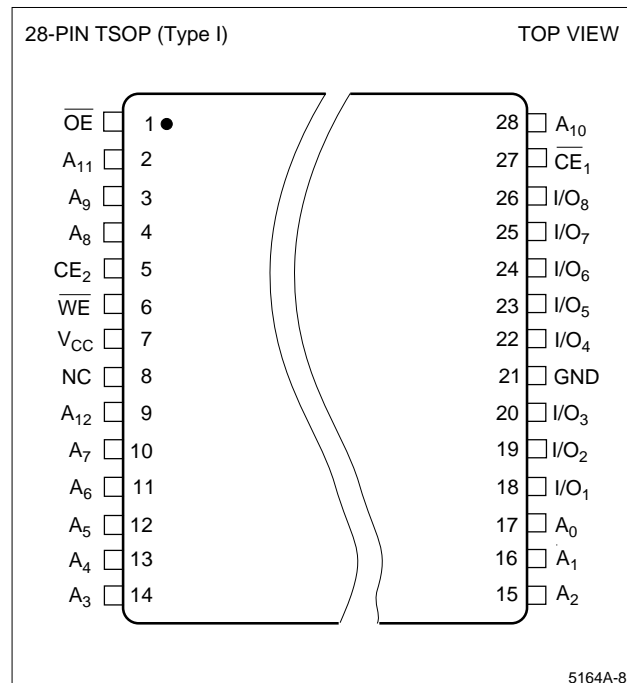

Figure 2. Pin Connections for TSOP Package

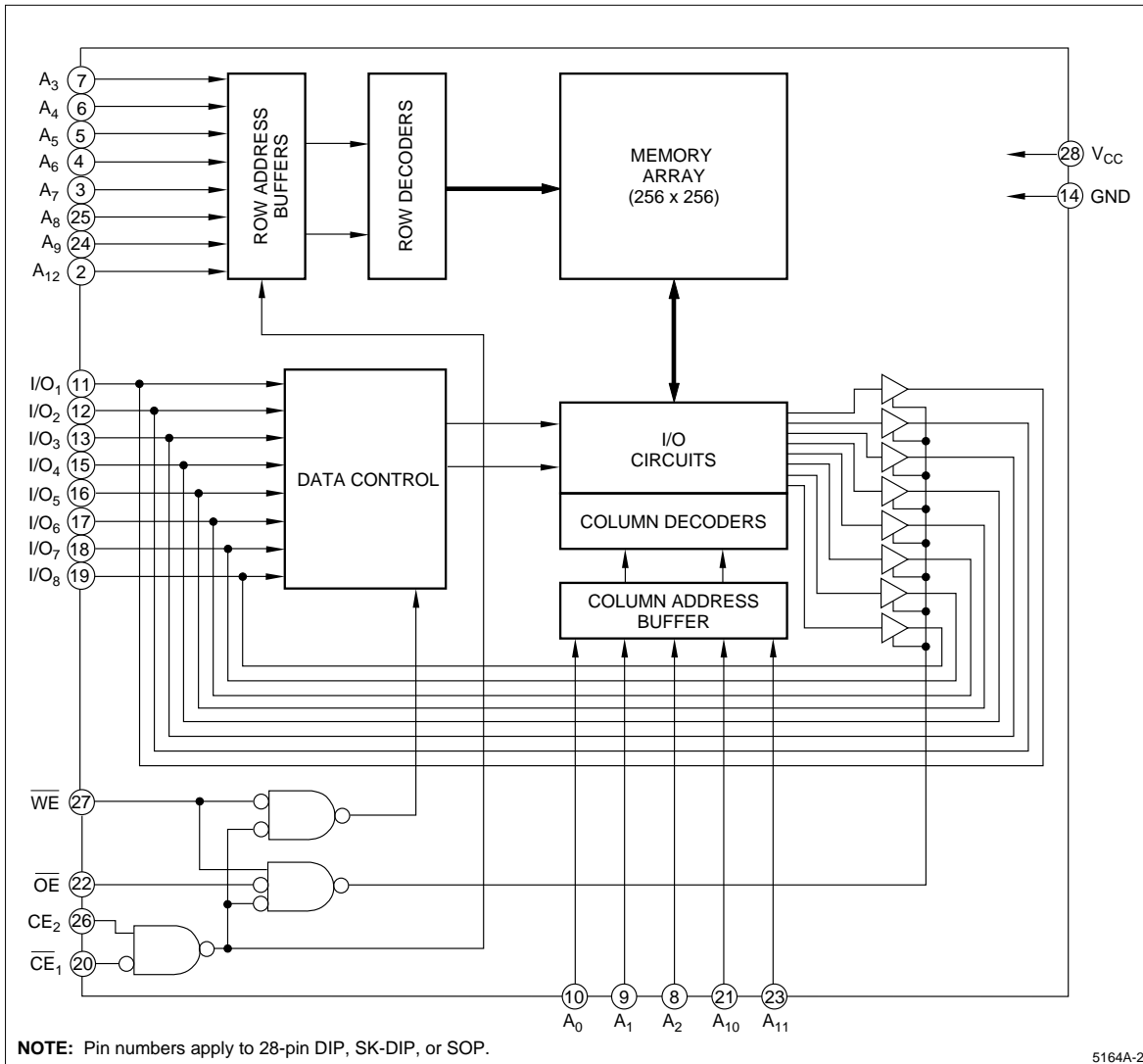

Figure 3. LH5164A/AH Block Diagram

PIN DESCRIPTION

SIGNAL	PIN NAME
A ₀ - A ₁₂	Address inputs
\overline{CE}_1 - CE ₂	Chip Enable input
\overline{WE}	Write Enable input
\overline{OE}	Output Enable input

SIGNAL	PIN NAME
I/O ₁ - I/O ₈	Data inputs and outputs
V _{CC}	Power supply
GND	Ground
NC	No connection

TRUTH TABLE

\overline{CE}_1	CE ₂	\overline{WE}	\overline{OE}	MODE	I/O ₁ - I/O ₈	SUPPLY CURRENT	NOTE
H	X	X	X	Deselect	High-Z	Standby (I _{SB})	1
X	L	X	X	Deselect	High-Z	Standby (I _{SB})	1
L	H	L	X	Write	D _{IN}	Operating (I _{CC})	1
L	H	H	L	Read	D _{OUT}	Operating (I _{CC})	
L	H	H	H	Output disable	High-Z	Operating (I _{CC})	

NOTE:
1. X = H or L

ABSOLUTE MAXIMUM RATINGS

PARAMETER	SYMBOL	80 ns	100 ns	UNIT	NOTE
		RATING	RATING		
Supply voltage	V _{CC}	-0.3 to +7.0	-0.3 to +7.0	V	1
Input voltage	V _{IN}	-0.3 to V _{CC} + 0.3	-0.3 to V _{CC} + 0.3	V	1, 2
Operating temperature	T _{opr}	-10 to +70	-10 to +70	°C	3
			-40 to +85	°C	4
Storage temperature	T _{stg}	-55 to +150	-55 to +150	°C	

NOTES:

- The maximum applicable voltage on any pin with respect to GND.
- V_{IN} (MIN.) = -3.0 V for pulse width ≤ 50 ns.
- LH5164A/AD/AN/AT
- LH5164AH/AHD/AHN/AHT

RECOMMENDED OPERATING CONDITIONS ¹

PARAMETER	SYMBOL	80 ns			100 ns			UNIT	NOTE
		MIN.	TYP.	MAX.	MIN.	TYP.	MAX.		
Supply voltage	V _{CC}	4.5	5.0	5.5	4.5	5.0	5.5	V	
Input voltage	V _{IH}	2.2		V _{CC} + 0.3	2.2		V _{CC} + 0.3	V	
	V _{IL}	-0.3		0.8	-0.3		0.8	V	2

NOTES:

- T_A = -10 to +70°C (LH5164A/AD/AN/AT), T_A = -40 to +85°C (LH5164AH/AHD/AHN/AHT).
- V_{IN} (MIN.) = -3.0 V for pulse width ≤ 50 ns.

DC CHARACTERISTICS ¹ (V_{CC} = 5 V ± 10%)

PARAMETER	SYMBOL	CONDITIONS	MIN.	MAX.	UNIT	NOTE	
Input leakage current	I _{LI}	V _{IN} = 0 to V _{CC}	-1.0	1.0	μA		
Output leakage current	I _{LO}	$\overline{CE}_1 = V_{IH}$ or $CE_2 = V_{IL}$ or $OE = V_{IH}$ or $WE = V_{IL}$ V _{I/O} = 0 to V _{CC}	-1.0	1.0	μA		
Operating current	I _{CC}	$\overline{CE}_1 = V_{IL}$, V _{IN} = V _{IL} or V _{IH} CE ₂ = V _{IH} , Outputs open		55	mA		
		$\overline{CE}_1 = V_{IL}$, V _{IN} = V _{IL} or V _{IH} CE ₂ = V _{IH} , Outputs open	t _{CYCLE} = 80 ns	45		2	
		$\overline{CE}_1 = V_{IL}$, V _{IN} = V _{IL} or V _{IH} CE ₂ = V _{IH} , Outputs open	t _{CYCLE} = 100 ns	50		3	
Standby current	I _{SB1}	$\overline{CE}_1 = V_{IH}$ or $CE_2 = V_{IL}$		5	mA		
		CE ₂ ≤ 0.2 V or $\overline{CE}_1 ≥ V_{CC} - 0.2 V$	T _A ≤ 70°C	1.0		μA	2, 3, 4
			T _A ≤ 85°C	3.0		μA	3, 4
Output voltage	V _{OL}	I _{OL} = 2.1 mA		0.4	V		
	V _{OH}	I _{OH} = -1 mA	2.4				

NOTES:

- T_A = -10 to 70°C (LH5164A/AD/AN/AT), T_A = -40 to +85°C (LH5164AH/AHD/AHN/AHT)
- LH5164A/AD/AN/AT
- LH5164AH/AHD/AHN/AHT
- CE₂ should be ≥ V_{CC} - 0.2 V or ≤ 0.2 V when $\overline{CE}_1 ≥ V_{CC} - 0.2 V$

AC CHARACTERISTICS ¹(1) READ CYCLE ($V_{CC} = 5\text{ V} \pm 10\%$)

PARAMETER	SYMBOL	80 ns		100 ns		UNIT	NOTE	
		MIN.	MAX.	MIN.	MAX.			
Read cycle time	t_{RC}	80		100		ns		
Address access time	t_{AA}		80		100	ns		
Chip enable access time	(\overline{CE}_1)	t_{ACE1}	80		100	ns		
	(CE_2)	t_{ACE2}	80		100	ns		
Output enable access time	t_{OE}		40		40	ns		
Output hold time	t_{OH}	10		10		ns		
Chip enable to output in Low-Z	(\overline{CE}_1)	t_{LZ1}	10		10	ns	1	
	(CE_2)	t_{LZ2}	10		10	ns	1	
Output enable to output in Low-Z	t_{OLZ}	5		5		ns	1	
Chip enable to output in High-Z	(\overline{CE}_1)	t_{HZ1}	0	30	0	30	ns	1
	(CE_2)	t_{HZ2}	0	30	0	30	ns	1
Output disable to output in High-Z	t_{OHZ}	0	20	0	20	ns	1	

(2) WRITE CYCLE ($V_{CC} = 5\text{ V} \pm 10\%$)

PARAMETER	SYMBOL	80 ns		100 ns		UNIT	NOTE
		MIN.	MAX.	MIN.	MAX.		
Write cycle time	t_{WC}	80		100		ns	
Chip enable to end of write	t_{CW}	70		80		ns	
Address valid to end of write	t_{AW}	70		80		ns	
Address setup time	t_{AS}	0		0		ns	
Write pulse width	t_{WP}	60		60		ns	
Write recovery time	t_{WR}	0		0		ns	
Data valid to end of write	t_{DW}	40		40		ns	
Data hold time	t_{DH}	0		0		ns	
Output active from end of write	t_{OW}	10		10		ns	2
\overline{WE} to output in High-Z	t_{WZ}	0	30	0	30	ns	2
\overline{OE} to output in High-Z	t_{OHZ}	0	20	0	20	ns	2

NOTES:

- $T_A = -10$ to $+70^\circ\text{C}$ (LH5164A/AD/AN/AT), $T_A = -40$ to $+85^\circ\text{C}$ (LH5164AH/AHD/AHN/AHT)
- Active output to high-impedance and high-impedance to output active tests specified for a ± 200 mV transition from steady state levels into the test load.

AC TEST CONDITIONS

PARAMETER	MODE	NOTE
Input voltage amplitude	0.6 to 2.4 V	
Input rise/fall time	10 ns	
Timing reference level	1.5 V	
Output load conditions	1TTL + C_L (100 pF)	1

NOTE:

- Includes scope and jig capacitance.

CAPACITANCE ¹ ($T_A = 25^\circ\text{C}$, $f = 1\text{ MHz}$)

PARAMETER	SYMBOL	CONDITIONS	MIN.	TYP.	MAX.	UNIT
Input capacitance	C_{IN}	$V_{IN} = 0\text{ V}$			7	pF
Input/output capacitance	$C_{I/O}$	$V_{IO} = 0\text{ V}$			10	pF

NOTE:

1. This parameter is sampled and not production tested.

DATA RETENTION CHARACTERISTICS ¹

PARAMETER	SYMBOL	CONDITIONS	MIN.	MAX.	UNIT	NOTE
Data retention voltage	V_{CCDR}	$\overline{CE}_2 \leq 0.2\text{ V}$ or $\overline{CE}_1 \geq V_{CCDR} - 0.2\text{ V}$	2.0	5.5	V	2
Data retention current	I_{CCDR}	$V_{CCDR} = 3\text{ V}$, $\overline{CE}_2 \leq 0.2\text{ V}$ or $\overline{CE}_1 \geq V_{CCDR} - 0.2\text{ V}$	$T_A = 25^\circ\text{C}$	0.2	μA	2, 3
			$T_A = 40^\circ\text{C}$	0.4	μA	2, 3
				0.6	μA	2, 3
		$V_{CCDR} = 3\text{ V}$, $\overline{CE}_2 \leq 0.2\text{ V}$ or $\overline{CE}_1 \geq V_{CCDR} - 0.2\text{ V}$	$T_A = 25^\circ\text{C}$	0.2	μA	2, 4
			$T_A = 70^\circ\text{C}$	0.6	μA	2, 4
				1.5	μA	2, 4
Chip disable to data retention	t_{CDR}		0		ns	
Recovery time	t_R		t_{RC}		ns	5

NOTES:

1. $T_A = -10$ to $+70^\circ\text{C}$ (LH5164A/AD/AN/AT), $T_A = -40$ to $+85^\circ\text{C}$ (LH5164AH/AHD/AHN/AHT)
2. \overline{CE}_2 should be $\geq V_{CCDR} - 0.2\text{ V}$ or $\leq 0.2\text{ V}$ when $\overline{CE}_1 \geq V_{CCDR} - 0.2\text{ V}$
3. LH5164A/AD/AN/AT
4. LH5164AH/AHD/AHN/AHT
5. t_{RC} = Read cycle time

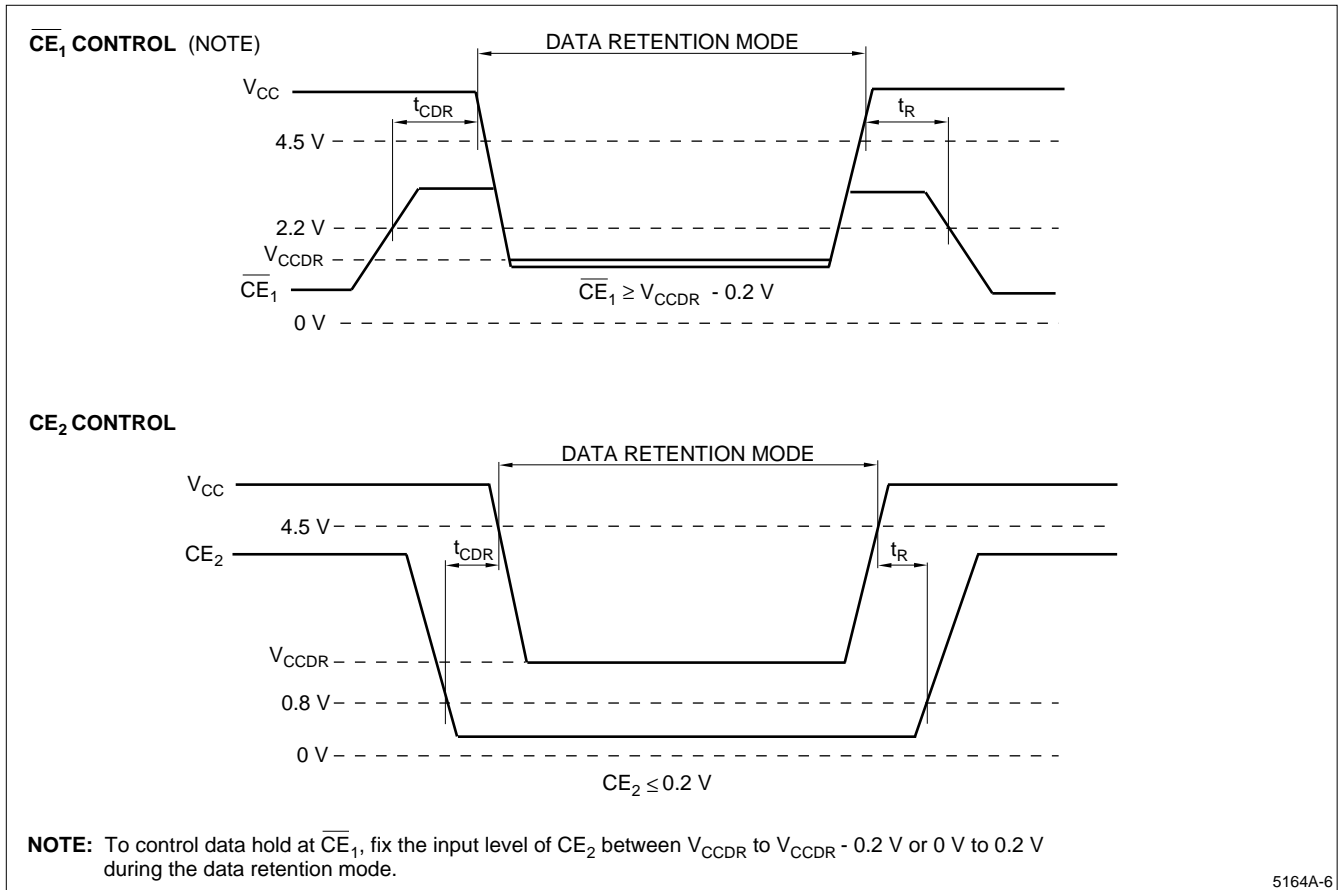

Figure 4. Low Voltage Data Retention

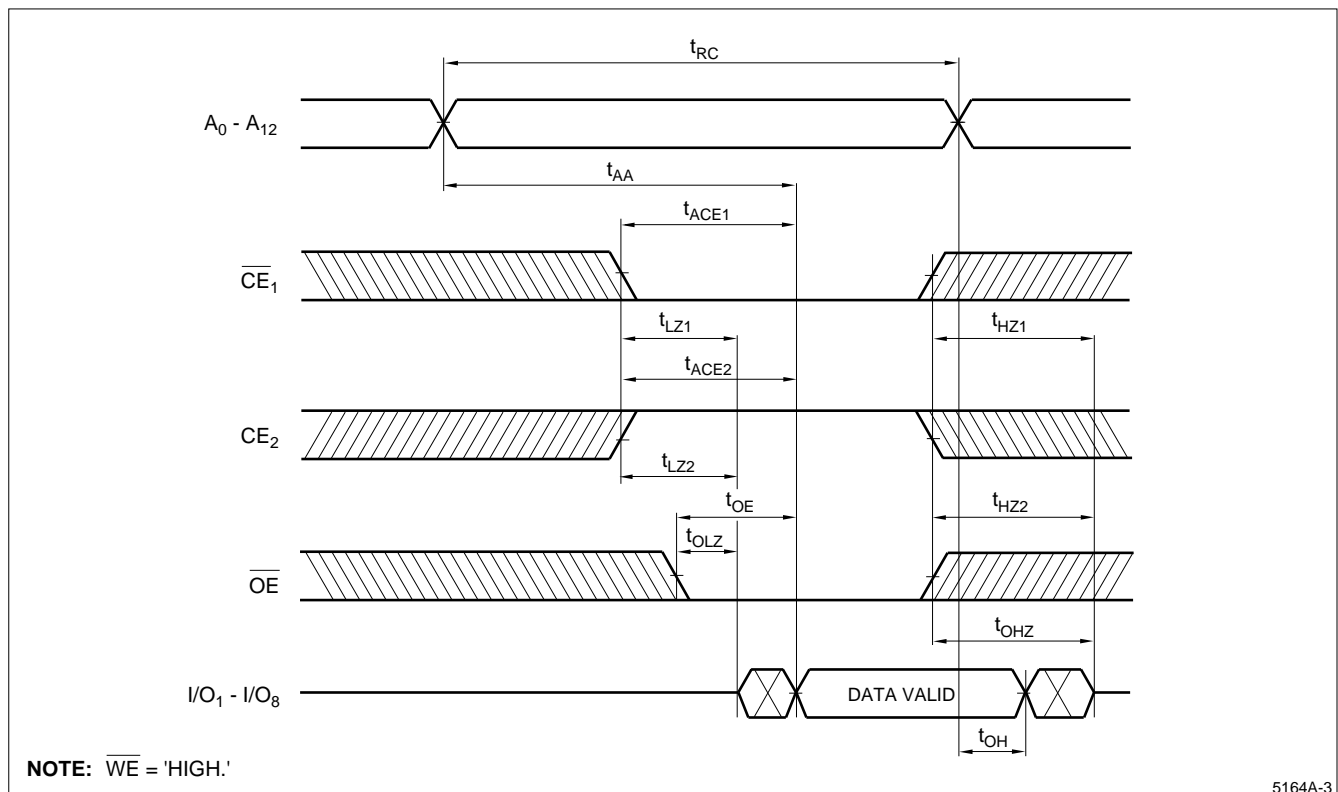
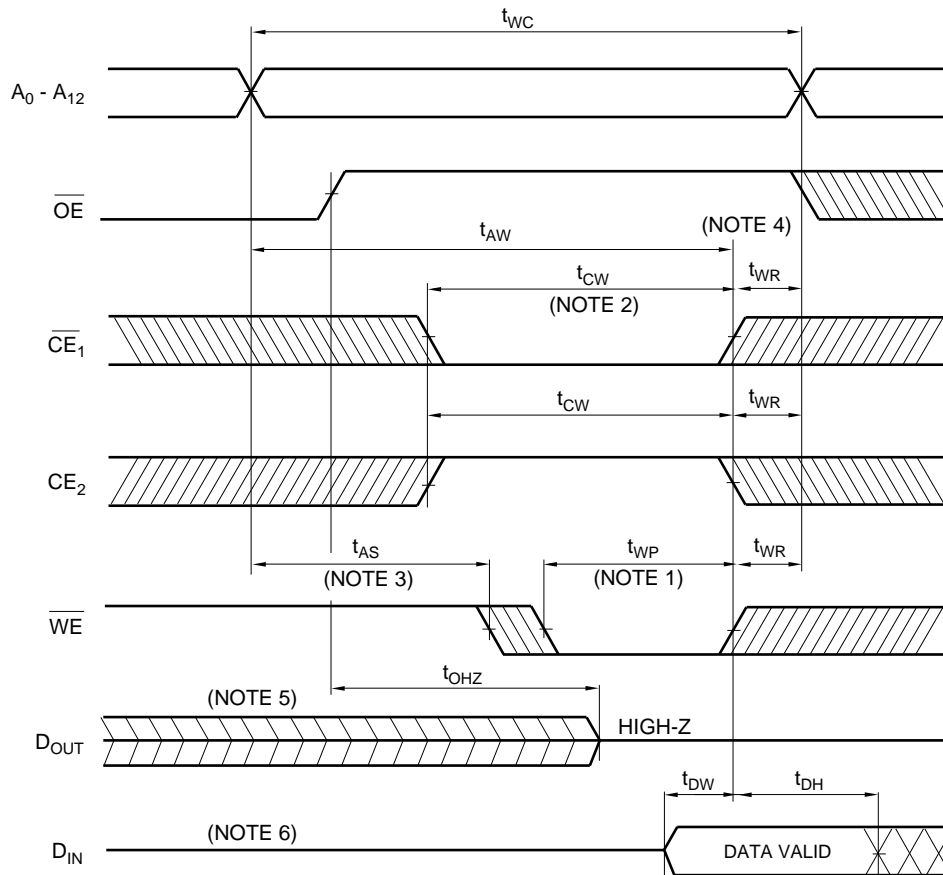

Figure 5. Read Cycle

**NOTES:**

1. The writing occurs during an overlapping period of $\overline{CE}_1 = \text{'LOW'}$, CE₂ = 'HIGH,' and $\overline{WE} = \text{'LOW'}$ (t_{WP}).
2. t_{CW} is defined as the time from the last occurring transition, either \overline{CE}_1 LOW transition or CE₂ HIGH transition, to the time when the writing is finished.
3. t_{AS} is defined as the time from address change to writing start.
4. t_{WR} is defined as the time from writing finish to address change.
5. If \overline{CE}_1 LOW transition or CE₂ HIGH transition occurs at the same time or after \overline{WE} LOW transition, the outputs will remain high-impedance.
6. While I/O pins are in the output state, input signals with the opposite logic level must not be applied.

5164A-4

Figure 6. Write Cycle 1

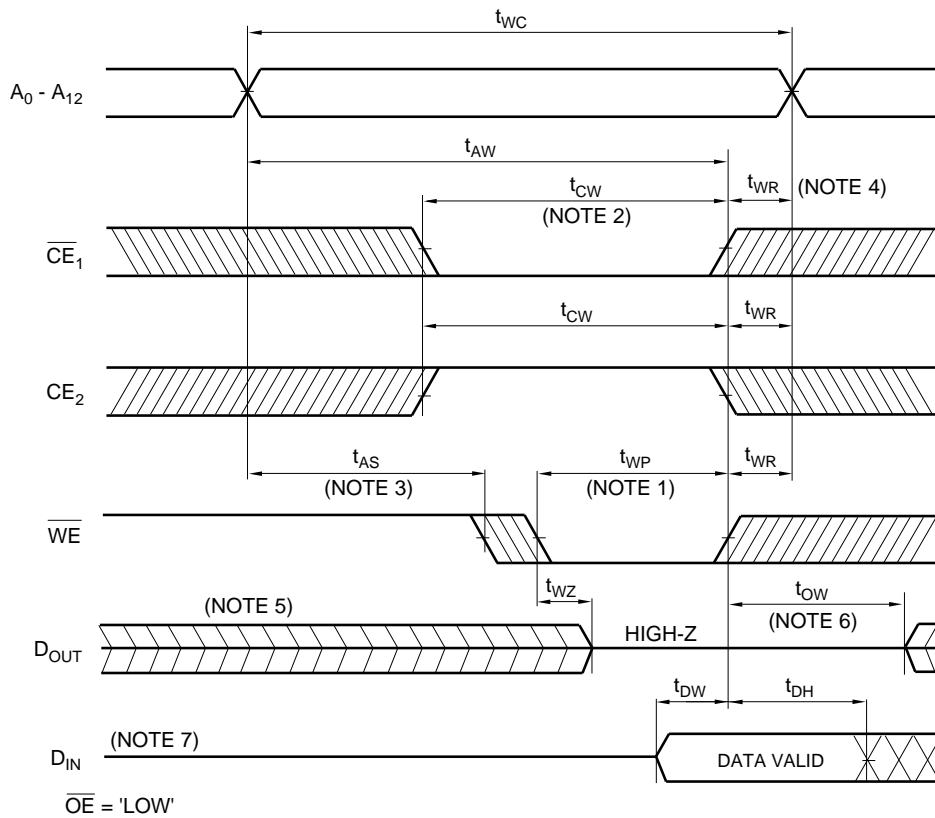

NOTES:

1. The writing occurs during an overlapping period of $\overline{CE}_1 = \text{'LOW'}$, $CE_2 = \text{'HIGH'}$, and $\overline{WE} = \text{'LOW'}$ (t_{WP}).
2. t_{CW} is defined as the time from the last occurring transition, either \overline{CE}_1 LOW transition or CE_2 HIGH transition, to the time when the writing is finished.
3. t_{AS} is defined as the time from address change to writing start.
4. t_{WR} is defined as the time from writing finish to address change.
5. If \overline{CE}_1 LOW transition or CE_2 HIGH transition occurs at the same time or after \overline{WE} LOW transition, the outputs will remain high-impedance.
6. If \overline{CE}_1 HIGH transition or CE_2 LOW transition occurs at the same time or before \overline{WE} HIGH transition, the outputs will remain high-impedance.
7. While I/O pins are in the output state, input signals with the opposite logic level must not be applied.

5164A-5

Figure 7. Write Cycle 2

PACKAGE DIAGRAMS

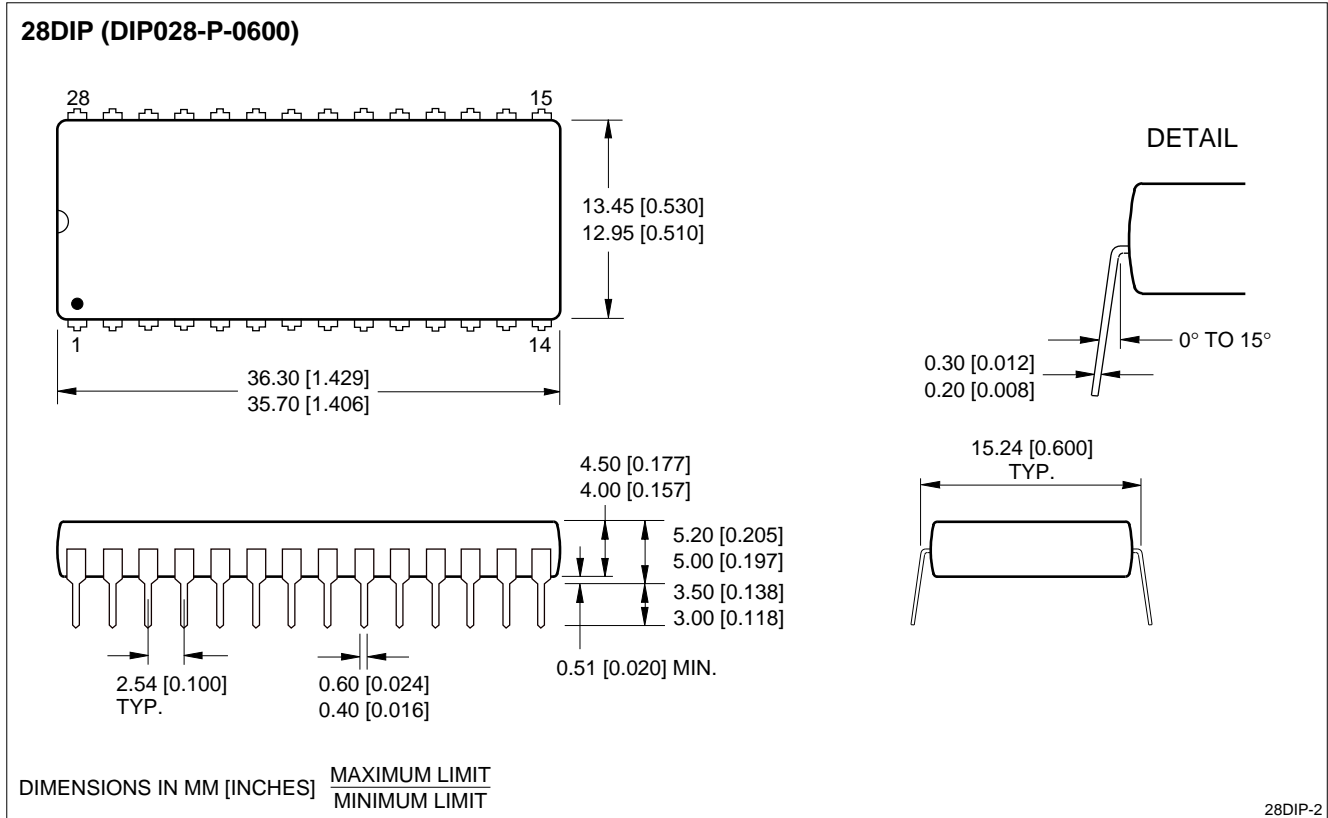

28-pin, 600-mil DIP

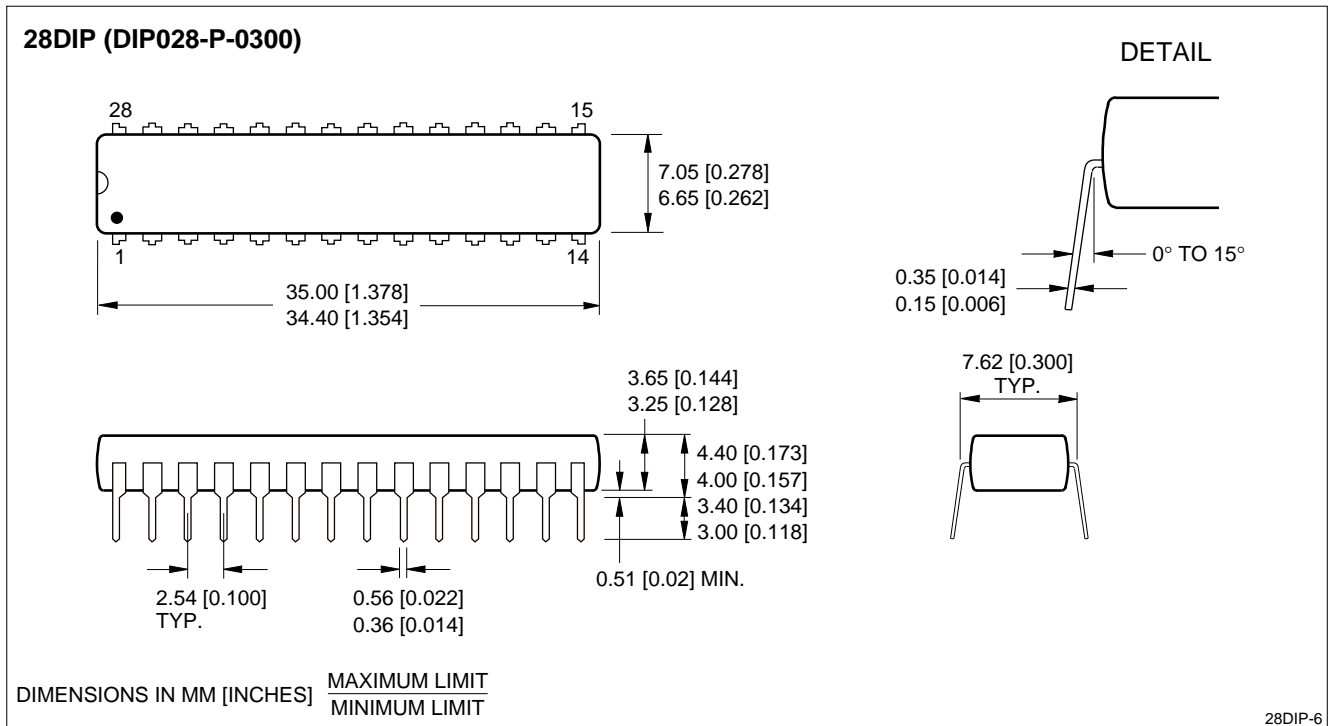

28-pin, 300-mil SK-DIP

28SOP (SOP028-P-0450)

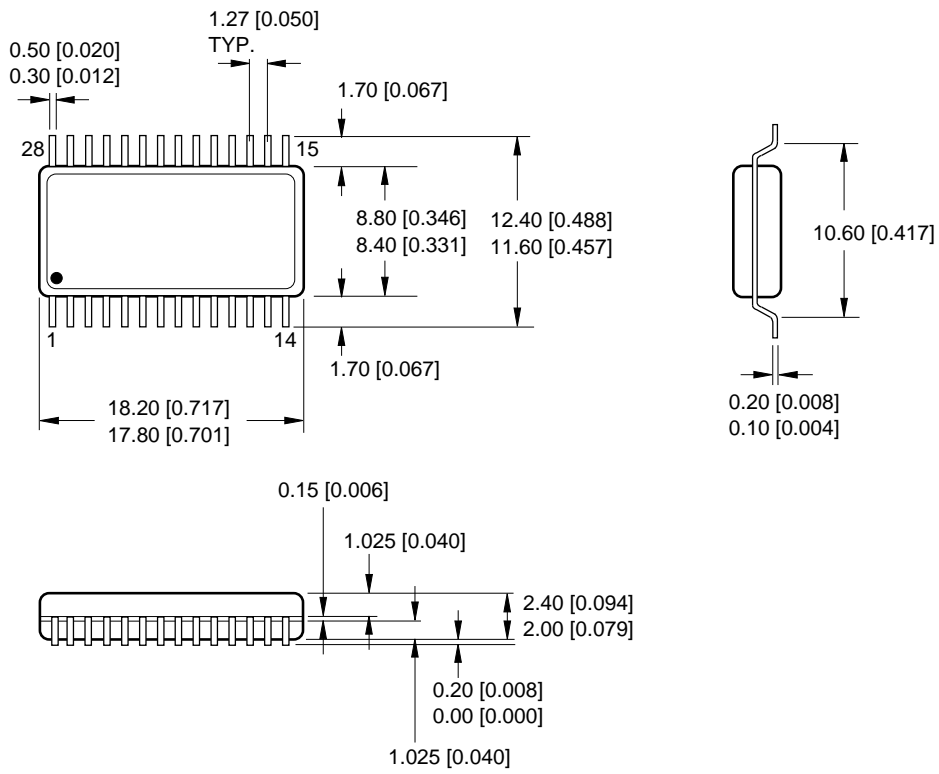

DIMENSIONS IN MM [INCHES] MAXIMUM LIMIT
MINIMUM LIMIT

28SOP

28-pin, 450-mil SOP

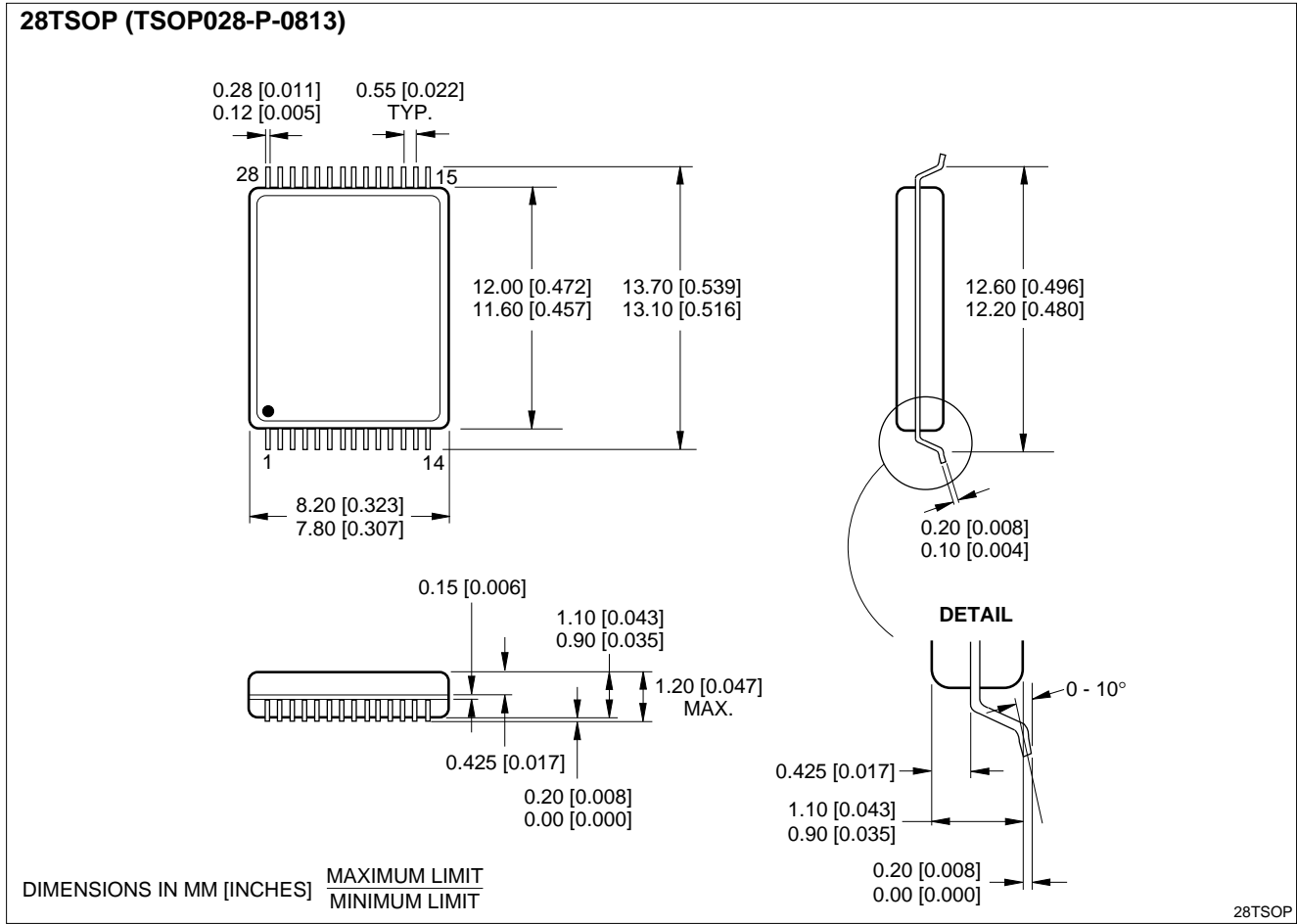

28-pin, 8 × 13 mm² TSOP (Type I)

ORDERING INFORMATION

LH5164A	X	X	- ##	L
Device Type	Operating Temperature	Package	Speed	Power
				Low-power standby
			{ 10 100 80 80	Access Time (ns)
				{ Blank 28 pin, 600-mil DIP (DIP028-P-0600) D 28-pin, 300-mil SK-DIP (SK-DIP028-P-0300) N 28-pin, 450-mil SOP (SOP028-P-0450) T 28-pin, 8 x 13 mm ² TSOP (Type I) (TSOP028-P-0813)
				{ Blank -10 to 70°C H -40 to +85°C
CMOS 64K (8K x 8) Static RAM				
Example: LH5164AD-10L (CMOS 64K (8K x 8) Static RAM, 100 ns, Low-power standby, 28-pin, 300-mil SK-DIP)				

5164A-7